



## Partnering simplicity with performance

Create a fresh outlook on life with the 950 Series High Performance Sliding Window. Utilising Capral's ecometal™, the 950 Series offers architectural style coupled with commercial quality and designer hardware to produce a system ideal for a wide range of applications - from commercial buildings and high-rise apartments, through to schools, universities and architecturally designed homes.

Designed to perform in harsh Australian conditions, the 950 Series provides peace of mind wherever it's installed. Combined with the 900 Series High Performance Sliding Door, you can relax because Capral has all of your bases covered.

Engineered to withstand some of the most extreme weather conditions Australia can offer, the 950 Series offers a wide range of possible configurations including Side-light, Top-light and Low-light and may be either single or double glazed.

Integrating directly into existing Capral Commercial framing systems, you can experience a flawless site line with the modern look and sleek lines expected in today's architecturally driven residential and commercial markets.

Offering a maximum panel height of 1800mm and a maximum panel width of 1200mm, it is rated to withstand Serviceability Wind Pressure up to 7,000 pa, Ultimate Wind Pressure up to 9,000 pa and has Water Penetration Resistance up to 600pa.

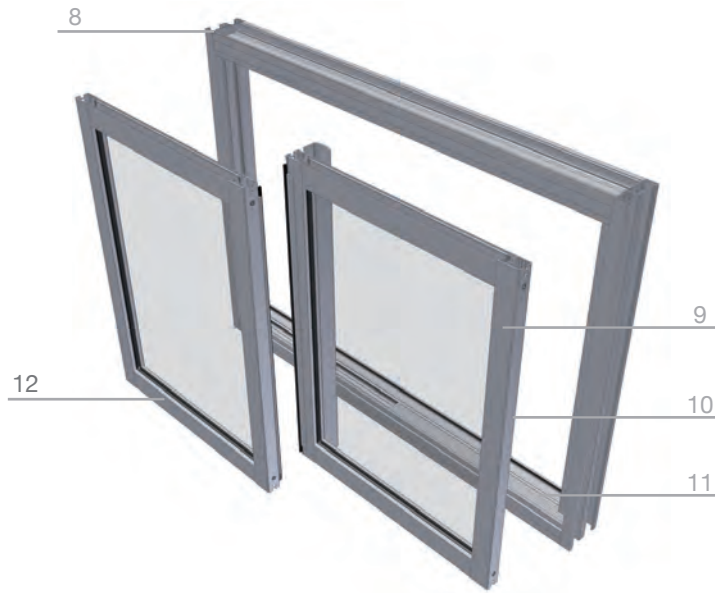
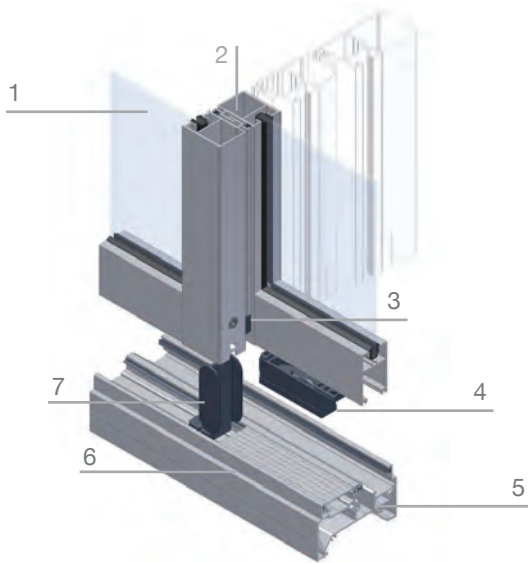

1. Single or double glazed options
2. Range of stiles and interlocks to meet performance requirement
3. Anti-lift/Infill block
4. Height adjustable standard or stainless steel roller opticals
5. Replaceable sill track
6. Stepped head/sill to maintain site line coupled with 400 series side light
7. Hidden fixed panel bracket
8. Precut gaskets to improve water penetration ratings
9. Super clean lines minimise dust & dirt
10. Handle options with vent lock
11. Optional threshold allowing external security/fly screening
12. Purpose designed seals to ensure superior product performance

## Superior features and high class design



- Dedicated single and double glazed panel options
- Stiles can be orientated depending on the desired configuration
- Flyscreen system integrated with outer frame
- Compatible with Capral Commercial framing systems
- Purpose designed components optimise system performance, function and aesthetics

### Product Specifications

- Serviceability Wind Pressure: Up to 7000 Pa\*
- Ultimate Wind Pressure: Up to 9000 Pa\*
- Water Penetration Resistance: Up to 600 Pa\*
- Maximum Panel Height: 1800mm
- Maximum Panel Width: 1200mm
- Maximum Panel Weight: 64kg
- Acoustic Rating: Up to 32 STC and 32 RW (-1 ; -2)

\* Dependant on size, configuration, sill & stile type  
(Refer to your account manager or AGS technical manual)

Contact your local AGS fabricator for further details.

